

Dock Levelers

101

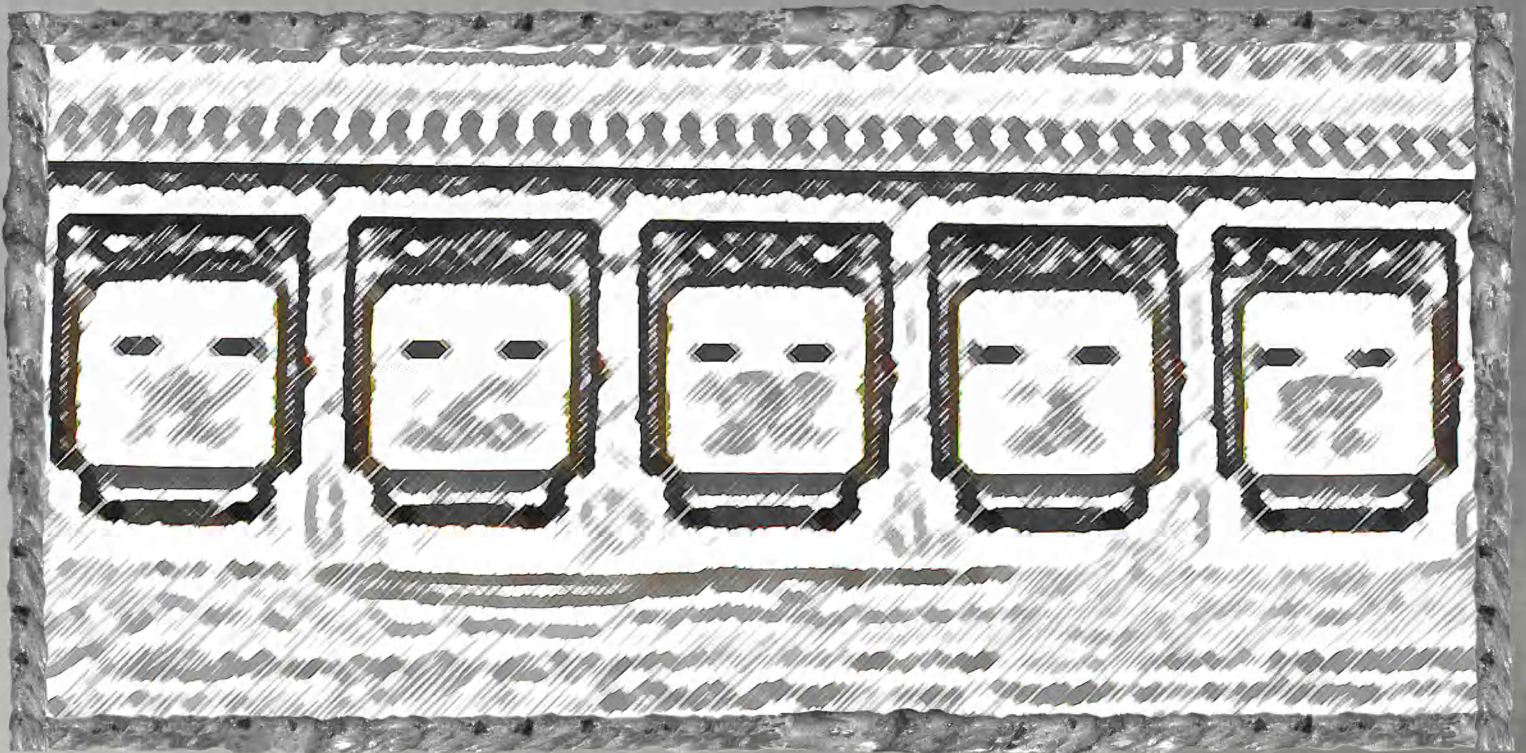

LDDEM

LOADING DOCK EQUIPMENT MANUFACTURERS

A Product Section of Material Handling Industry, MHI

What You Always Wanted to Know About Dock Levelers But Were Afraid to Ask

Just what the heck is a dock leveler?

A dock leveler is a piece of equipment that is usually either mounted to the dock face or recessed into a pit at a loading dock door allowing movement of industrial vehicles between a building and a transport vehicle.

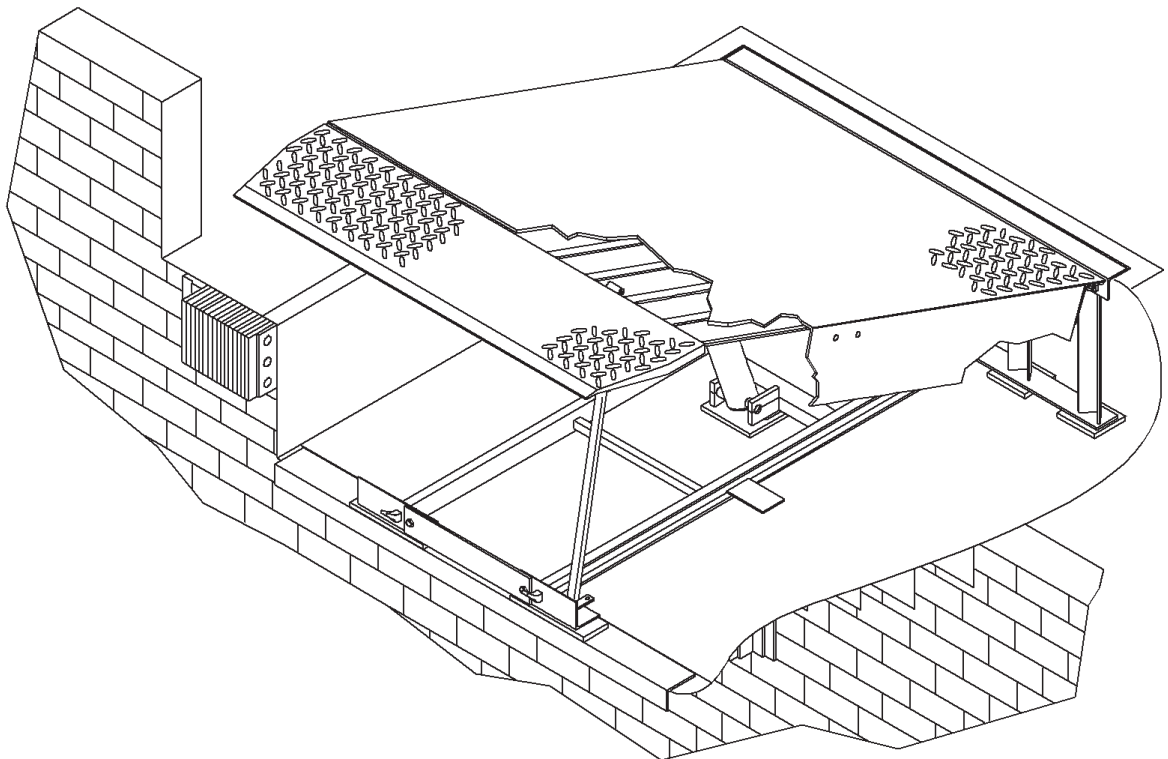

Common Terms and Definitions

What do I need to know before I can start selecting a dock leveler for my application?

You might want to know some common terms and definitions:

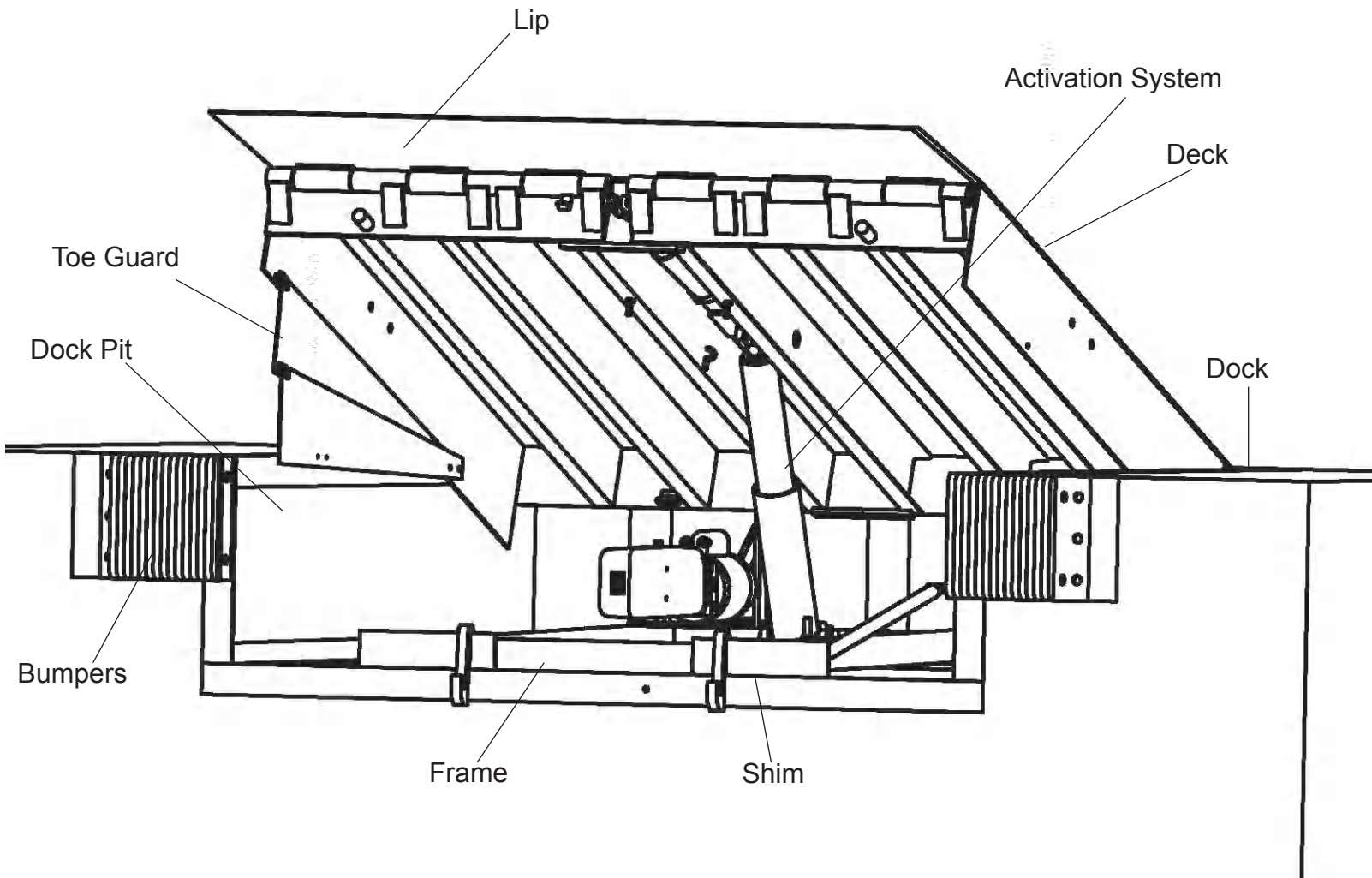



Common Terms and Definitions

Activation System: The activation system provides the motive power of the dock leveler. These systems may or may not require external power interfaces. Typical activation systems are mechanical (springs), pneumatic (air bladders) and hydraulic.

Attachments: This term refers to implements that can be added to a fork truck for handling a load. Attachments such as clamps, slip sheet forks and carpet poles can have an effect on capacity and should be considered in selecting a dock leveler.

Bumpers: These are used to prevent the transport vehicle from directly contacting and damaging the building, dock leveler or vehicle restraint. They are usually made of rubber. Bumper sizes and projections vary, based on vehicles serviced and other factors such as driveway slope.

Capacity: The manufacturer's capacity tag rating may not reflect the gross roll-over load for a specific dock leveler. Capacity is the rating of the load that the manufacturer of the dock leveler deems to be appropriate for the design, based on considerations of the characteristics of the user's application. The required capacity of a dock leveler for a specific application is usually determined by taking the GVW and applying a complexity factor to it. The complexity factor is typically determined by a set of characteristics that are present at the particular application. These characteristics may include, but are not limited to: the heaviest fork lift and load (GVW) being driven across the dock leveler; the number of fork lift cycles driving across the dock leveler; the speed of fork lift moving across the dock leveler; the life expectation of the dock leveler; the loading slope above or below dock level; the use of three vs four wheel lift trucks; whether there are attachments on the front end of the lift truck; the lip length as well as other considerations. The authorized sales representative of the manufacturer can help determine the capacity of the dock leveler that is required for a specific application.

Deck: The deck assembly is the major part of the structure that is driven over. Most decks have some type of anti-skid surface such as a tread plate surface to provide traction at the various working angles. The deck assembly pivots at the back end of the dock leveler - the end of the dock leveler that is furthest from the transport vehicle. The dock leveler has a hinged lip attached to the other end.

Dock: This is the area of a building where loading and/or unloading of transport vehicles takes place.

Dock Level: This term involves the vertical level that conforms to the building's floor surface.



Common Terms and Definitions

Dock Pit: The pit is the recessed opening in the building's floor that accommodates the pit dock leveler. Most pits are lined along the edges with structural steel angles that are embedded in the concrete.

Frame: The frame assembly is the supporting structure for a dock leveler.

Gross Vehicle Weight (GVW): The GVW is the combined weight of the material handling equipment (lift truck, pallet jack, etc) and the load. In other words, it is the total maximum weight moving across the dock leveler.

Lip: The lip assembly is usually pivotally attached to the deck assembly and pivots from a vertical stored position to a position that rests on the transport vehicle's floor. Lips are usually made with a tread plate that is similar to the deck.

Load: The load is the weight of a typical individual pallet on a transport vehicle. For typical capacity calculations there are a maximum of (20) twenty loads per transport vehicle.

Shift: This term refers to the working shift at the building. For capacity calculation purposes, a typical capacity calculation would involve a maximum of (8) eight trailers per shift.

Shim: These are steel plates that maybe used to help level pit-mounted dock levelers. Shims may be placed under the frame structure and would be welded in place in order to provide a structural load path to the building's foundation.

Toe Guard: It is a shield that is mounted flush to the side of a deck assembly in order to provide toe protection when the dock leveler is above dock level.

Transport Vehicle: This is a cargo carrying vehicle such as a truck, semi-trailer, trailer or railcar.

Working Range: The recommended range of vertical travel above and below dock level for which loading and unloading can take place.

Types of Dock Levelers - Pit Levelers

What kinds of dock levelers are there?

There are many different kinds of dock levelers. These include the following common types, but may also include special designs that are unique to an individual manufacturer;

Pit leveler - This type of dock leveler is found in a recessed concrete opening in a building's concrete at the dock door. There are three major sub-categories of such pit levelers:

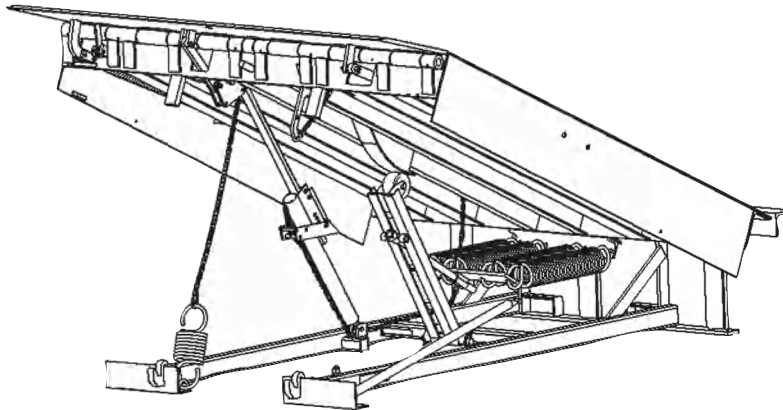

Mechanical Pit Leveler This is the most common of the pit leveler category and typically the least expensive. This leveler style uses a mechanical spring system to raise the leveler and is typically “upward biased.” This means that the spring is tending to force the leveler deck to rise up all of the time and a restraining device is preventing that motion. No electrical power supply at the dock is required for such a mechanical leveler. These levelers tend to be the most expensive to service and to maintain over their life.

Types of Dock Levelers - Pit Levelers

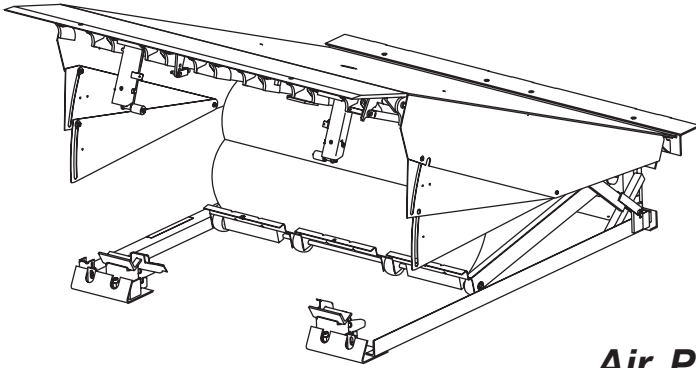

Air Pit Leveler This type uses a pneumatic bag system of some type to raise and lower the leveler deck. Obviously, this leveler requires some type of electrical power source - either at the dock or adjacent to it. Most typically, this power source would be standard 110v power. Generally, these levelers are moderately more expensive than mechanical levelers but can involve reduced service and maintenance requirements when compared to mechanical units.

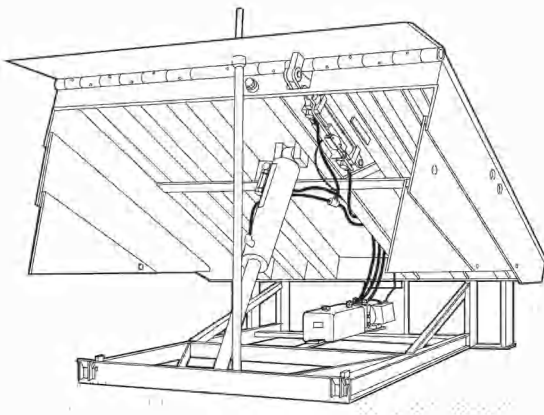

Hydraulic Pit Leveler This is the most versatile of the pit style levelers. A hydraulic cylinder is used to raise and to lower the deck, while another is typically used to operate the lip. These levelers may come in various configurations and may be powered by everything from 110V single phase to 575V three-phase.

The hydraulic option gives you more versatility than either mechanical or air dock levelers and typically would have lower service and maintenance costs.

Types of Dock Levelers - Vertical & Rail Dock Levelers

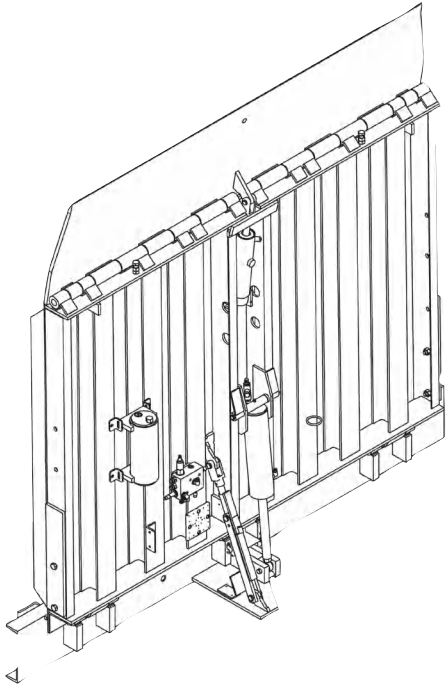

Vertical Leveler A vertical leveler is exactly what the name implies - a dock leveler that is stored in a vertical position. Why is this desirable? This allows you to store the leveler inside the building and to close your dock door on concrete, instead of across the leveler, as is the case of a pit leveler. This should allow better environmental control in your building. These vertical levelers are often used in food service applications or areas where wash down is an issue. Vertical levelers are typically pit or shelf-mounted and hydraulically operated.

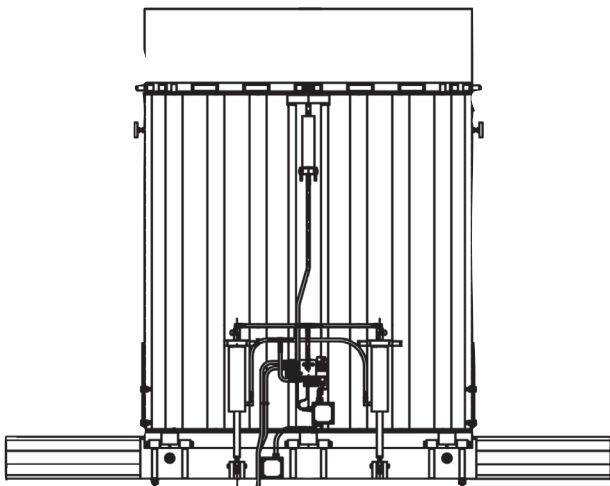

Rail Dock Leveler These levelers involve a variation on the vertical leveler and are used to service rail cars. They are usually mounted on a sliding rail that allows them to move horizontally along the rail track. They may either be manually or hydraulically moved along the track and are typically hydraulically operated levelers.

Types of Dock Levelers - Edge of Dock (EOD) & Top of Dock (TOD) Levelers

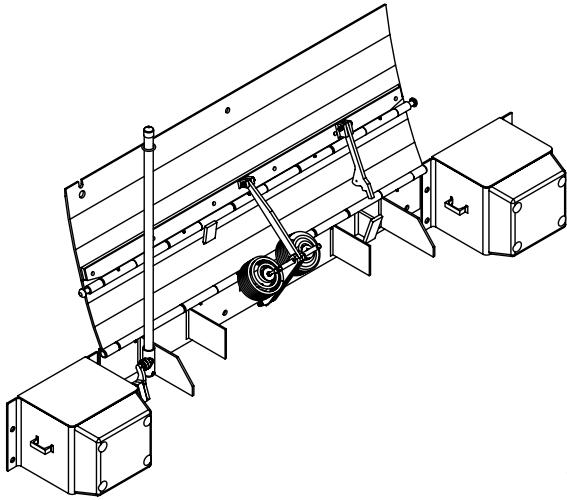

Edge of Dock (EOD) Leveler This is a simple device that is usually mechanically operated but may be pneumatically or hydraulically operated. It is often found mounted on the exterior wall of a building with an integral bumper set but may also be pit mounted. The EOD has a limited vertical operating range and is geared toward applications where the transport vehicle bed is at, or very near, the floor level of the building (dock level). These units are generally inexpensive when compared to a pit or vertical dock leveler but may be considered an upgrade from portable dock boards as they are fixed to the dock face and have some form of lift assistance (mechanical, air or hydraulic). A recommended normal working range of an EOD is typically +/- 3 inches.

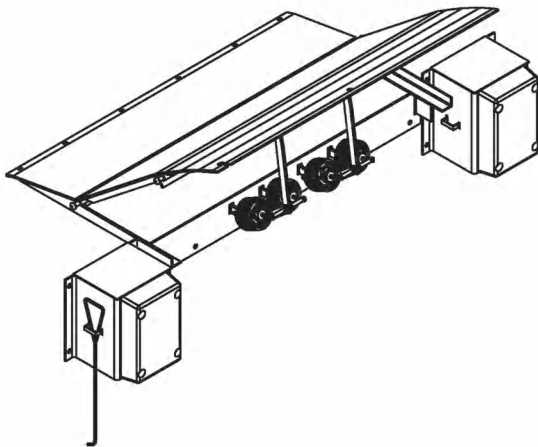

Top of Dock (TOD) Leveler This is a version of an EOD leveler and is typically mounted to the floor surface and the leading edge of the dock face of the building. It generally requires minimal or no concrete work. The working range of these units is intended to provide primarily above-dock working range.



More Information

How do I find out more?

You can contact the Loading Dock Equipment Manufacturer's website at www.MHI.org/LODEM

At the time this resource document was published, LODEM consisted of the following member companies:

4Front Entrematic
Blue Giant Equipment Corporation
Bluff Manufacturing, Inc.
NOVA Technology
Pentalift Equipment Corporation
Rite-Hite Corporation
Systems, Incorporated

DISCLAIMER OF LIABILITY. LODEM, the Material Handling Industry, MHI, and their members assume no responsibility and disclaim all liability of any kind, however arising, as a result of acceptance or use or alleged use of this Guide. User specifically understands and agrees that LODEM, the Material Handling Industry, MHI, their members, their officers, agents, and employees shall not be liable under any legal theory of any kind for any action or failure to act with respect to the proper selection of a material handling system as well as matters such as the service for which it will be used, the frequency of its use, matching its speed with manufacturing needs, budget or any other activity covered by This Guide. Any use of this information must be determined by the user to be in accordance with applicable federal, state, and local laws and regulations.

DISCLAIMER OF WARRANTY. LODEM, the Material Handling Industry, MHI, and their members make NO WARRANTIES of any kind, express, implied, or statutory, in connection with the information in this Guide and SPECIFICALLY DISCLAIM ALL IMPLIED WARRANTIES OF MERCHANTABILITY AND OF FITNESS FOR PARTICULAR PURPOSE.

INDEMNIFICATION. By referring to or otherwise employing This Guide, the user agrees to defend, protect, indemnify, and hold LODEM, the Material Handling Industry, MHI, their members, their officers, agents, and employees harmless from and against all claims, losses, expenses, damages, and liabilities, direct, incidental, or consequential, arising from acceptance or use or alleged use of this Guide, including loss of profits and reasonable attorneys' fees which may arise out of the acceptance or use or alleged use of this Guide. The intent of this provision and of the user is to absolve and protect LODEM, the Material Handling Industry, MHI, their members, their officers, agents, and employees from any and all loss relating in any way to this Guide, including those resulting from the user's own negligence.



LODEM

LOADING DOCK EQUIPMENT MANUFACTURERS



Loading Dock Equipment Manufacturers Product Section of
The Material Handling Industry, MHI
8720 Red Oak Boulevard, Suite 201
Charlotte, NC 28217-3992
Telephone: (704) 676-1190
Fax: (704) 679-1199
www.MHI.org/LODEM

© LODEM 2012



LODEM

LOADING DOCK EQUIPMENT MANUFACTURERS